

PSI-D



PSI-D is a wall mountable indoor biometric imaging hardware system that is optimised specifically for facial recognition. The device comprises of PSI's advanced camera technology and evenly distributed near infrared (NIR) illumination.

Designed to eliminate ambient lighting effects, spectral reflection, motion blur and image distortion, PSI-D utilises its hardware to produce high speed, high quality detailed imaging, ideal for exceptionally reliable facial recognition. The unit hardware is proven over many years, gaining major UK airport biometric security approval. The compact, lightweight design and simple wall mount connection ensures the device is extremely quick and easy to install. Interface cable connections are neatly and securely concealed.

PSI-D can be utilised within many environments. It is a low power device, which has been assessed and approved independently to international safety standards. PSI-D is an ITE device that can be operated within medical environments. A current working example of PSI-D is as a hospital patient safety device, detecting the individual to aid in verifying that they receive the correct treatment plan.

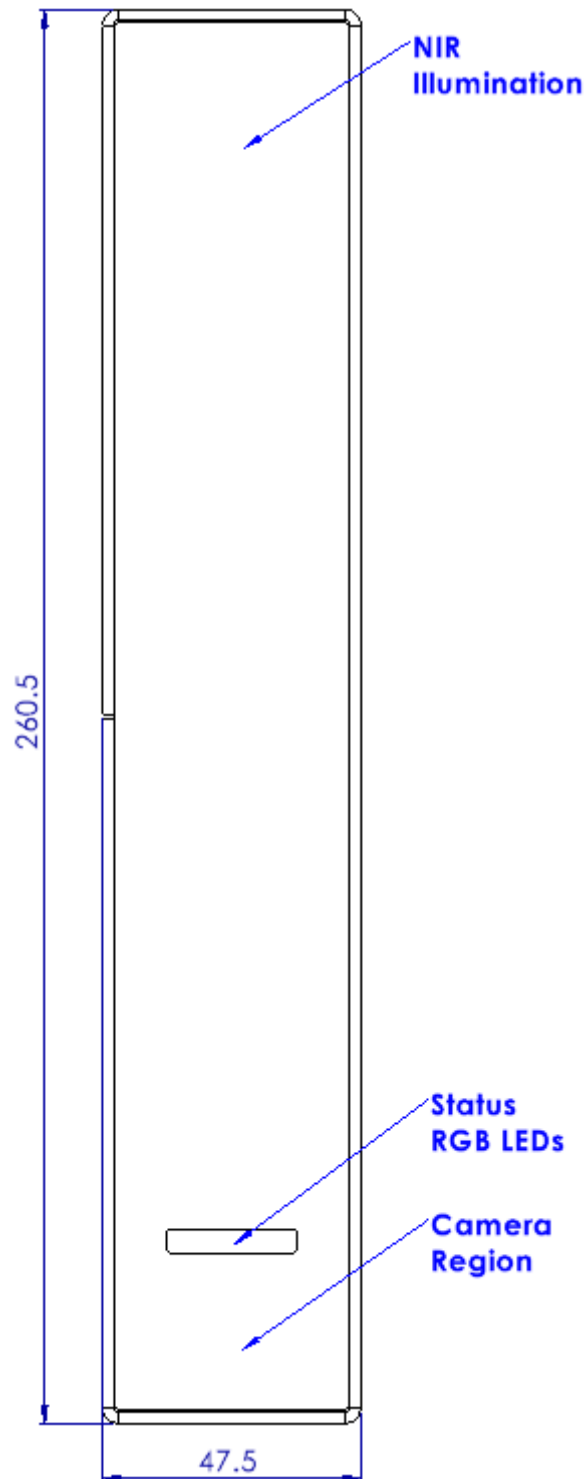

Figure 1a: Front and rear views of PSI-D Unit.

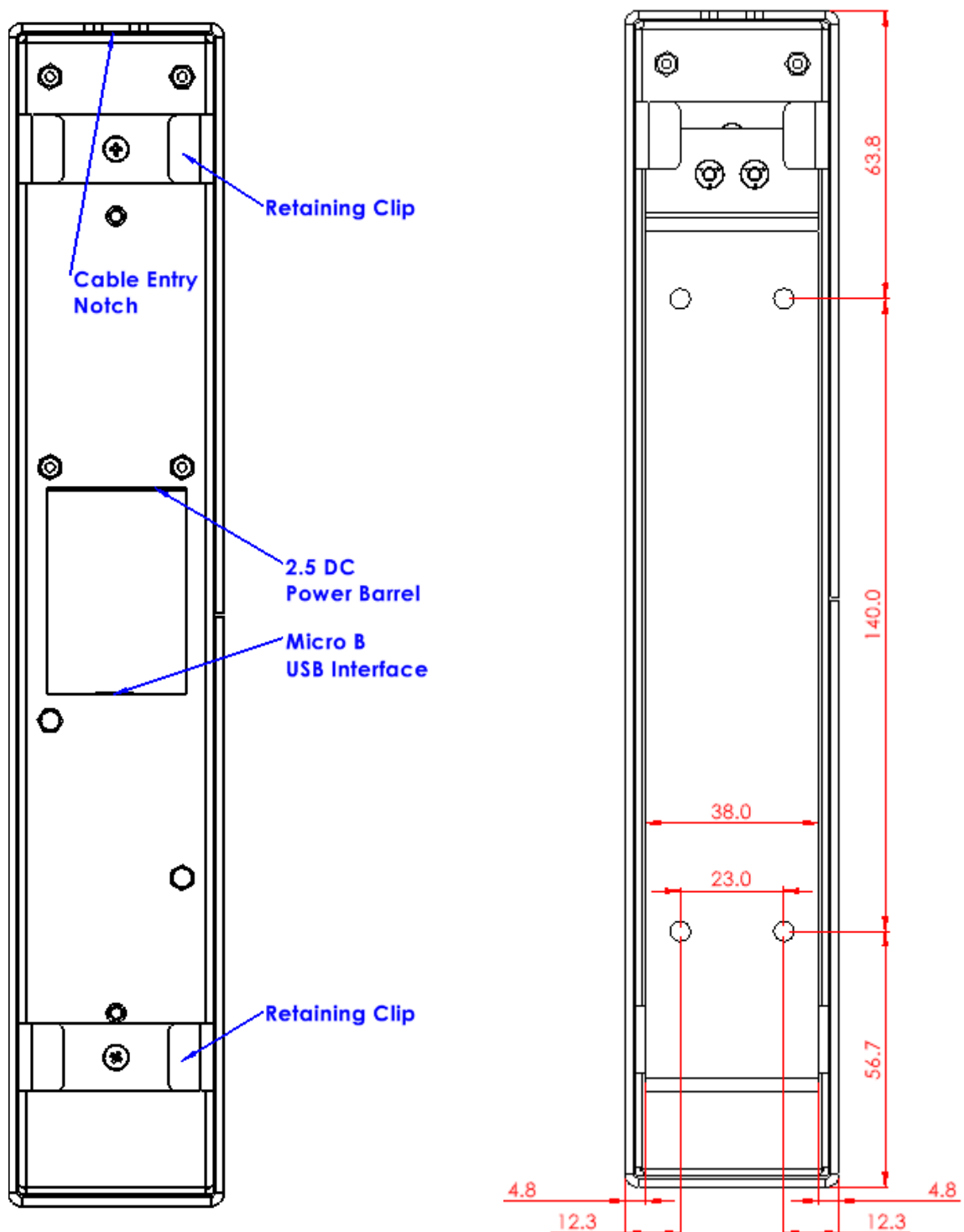

Figure 1b: Two diagrams of the Rear of PSI-D. The first without the wall mount plate fitted and the second with the wall mount plate fitted.

Specification

Camera

Resolution	Wide Video Graphics Array (WVGA) 752 x 480
Camera Features	High Speed Shutter Programmable watchdog for automatic renumeration <i>(recommended min 60 seconds extendible to 999.999s or off)</i>
Status LEDs	5 x RGB programmable over USB
Ambient temperature range	0°C to 60°C
Data transfer	USB2 High Speed Bulk transfer via winusb/libusb

LED Illumination

Wavelength	Near Infrared (NIR)
Supply voltage	12V DC <i>(Powered from certified power supply 100-240V 50/60Hz)</i>
Supply current idle mode	40mA typical
Supply current short-term peak	2.5A for 7mS
Power consumption idling	0.5W
Power consumption operating	0.8W typical
Maximum power consumption	4.2W (fuse limited)
Ambient temperature range	0°C to 60°C
Over temperature trip	80°C (75°C reset)

Dimensions

Size H x W x D	260.5mm x 47.5mm x 55.5mm
Weight Imaging unit	0.5kg
Outer case & backplate	0.5kg
Total weight	1kg

Approvals

Safety	IEC 62368-1:2014 (Second Edition) EN62368-1:2014+A11:2017 ¹ CSA/UL 62368-1: 2014 <i>Audio/Video, Information and communication technology equipment – Part 1: Safety requirements, Second Edition</i> ² AS/NZS 62368:1:2018
Eye Safety Artificial Optical Radiation	IEC 62471:2006, BS EN 62471:2008 (Classed Exempt)
EMC	EN55032:2015 (Conducted & Radiated) EN55035:2017 (Immunity)
RoHS	2011/65/EU Amended by 2015/863 <i>(Phthalates Compliant)</i>

¹ All the declared national differences (SNC and A-Deviations) have been applied for all EU countries. EU group differences CENELEC Common Modification (Group differences) to the IEC standard have been applied.

² NRTL 104048 MET File Number E114911

Installation

The PSI-D imaging system has a simple and quick two-stage installation.

The first stage is to mount the provided thin steel plate to the wall using the four mounting points. Please use fixings most appropriate for the wall material ensuring the plate is securely mounted. The 4.5mm mounting holes allow screw sizes up to No.8 to be used.

The recommended height for the camera lens is 1550mm from the floor as this allows subject heights from 1470mm to 1950mm to be seen by the camera (see figure 2).

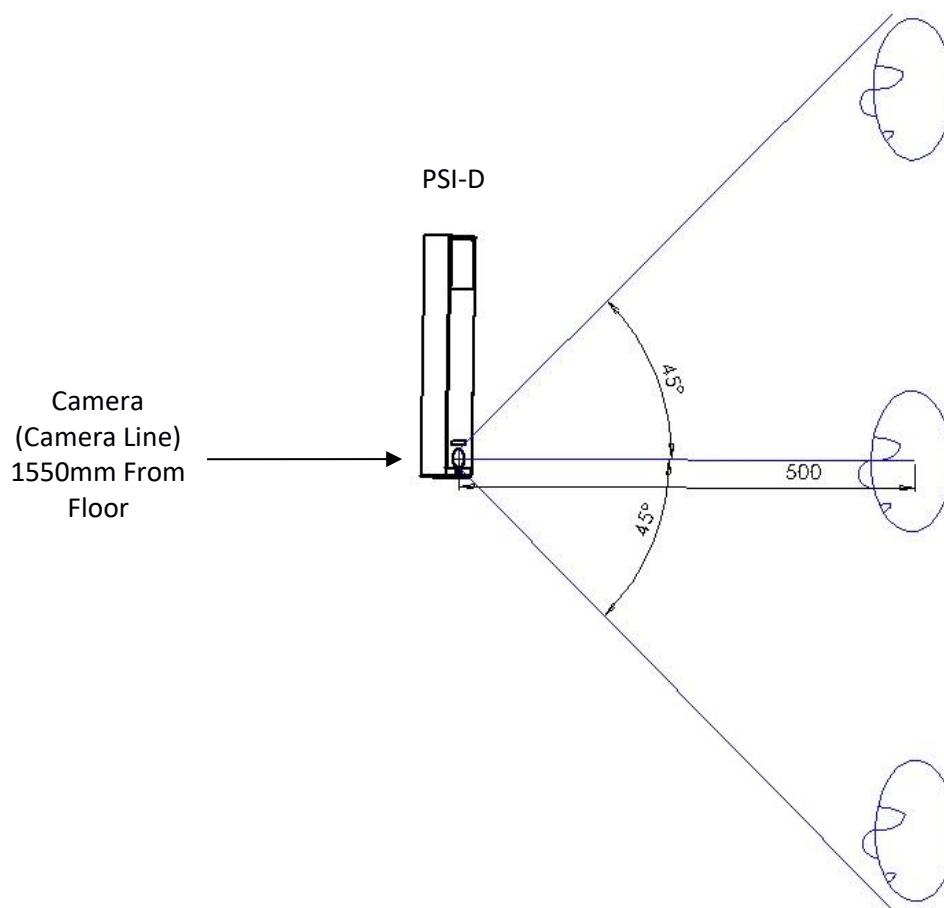

Figure 2: Recommended height of install showing head positions within camera range at 500mm from PSI-D.

To achieve this, the lower mounting holes on the wall plate should be 1590mm above floor. If more than one PSI-D terminal is being installed, these should be installed at similar height.

Note: For children and wheelchair users an additional lower unit is recommended, where the camera lens can cover a lower height range. In all instances, a clear floor area allowing the subject to be positioned approximately 500mm from the imaging system must be provided.

The camera requires two cables, a USB2 micro-B and a 2-core power cable, which is terminated with a 2.5mm DC barrel connector. These can be run from a suitable location however please note that the USB2 cable has a recommended maximum length of 3 metres. The maximum cable length is however always a function of the cable quality. The power supply provided should use cable rated at a minimum of 2.5A and should be mounted in accordance with local regulation. Fit a cable tie, such that the two cables can be secured in place once the wall plate has been secured to the wall.

Secure the wall plate with four mounting screws and route the cables such that there is enough length to connect the USB and power cable through the rectangular hole in the rear of the camera casing. This is normally around 250mm for the power cable and 350mm for the USB cable when measured from the cable tie point. The cables can now be secured in place with the cable tie.

Figure 3: First stage of install – Mounting of the steel plate to wall.

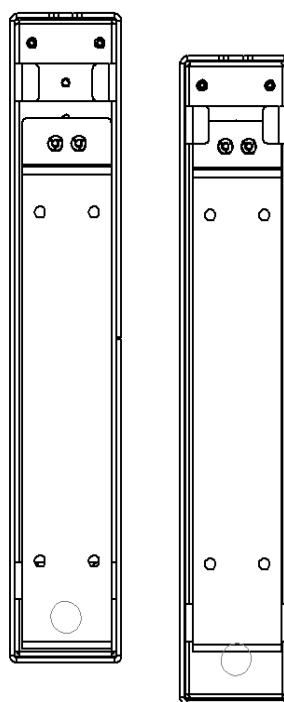
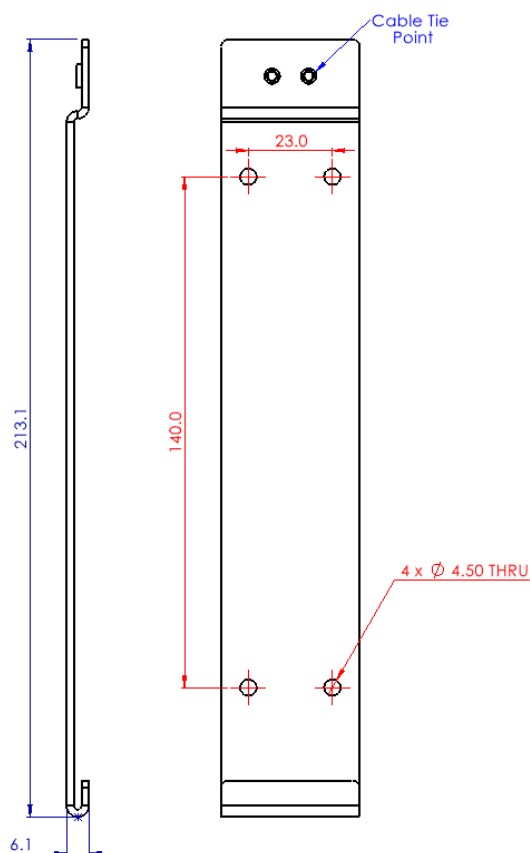

Line the bottom bracket of the camera wall casing to the locating bottom tab of the fixed wall mount. Sit the camera flush to the wall and apply pressure downwards from the top of the camera unit so the wall mount lines up and fits into the brackets at the back of the camera with a defined “click”. This will securely fit the camera flush to the wall. The camera should feel solid to the wall with little movement in any direction. It should take significantly applied pressure upwards from the bottom of the camera unit to unclick the unit to move it away from the wall.

Figure 4: Mounting of the camera to the fixed wall plate, rear view.

The camera can now be mounted by placing the camera over the wall bracket and pulling down into place, as explained in Figure 4.

Connect the USB cable to the host and apply power via the 12V power supply provided. The status LEDs will illuminate with a yellow central light. This indicates power is applied but the camera has not enumerated with the host. When enumeration is complete the yellow light will turn green and the system is ready for operation. The device can now reliably undertake facial recognition as directed by the host computer.

5. Cleaning and Maintenance

The PSI-D Imaging system is predominantly maintenance free. The system is designed to work indoor, without the presence of high dust levels. The outer casing and front screen can be cleaned, it is recommended that the front screen is kept clean of dust particles, especially within the areas of where the camera lens and LED illumination are located, as seen in shaded blue areas of figure 5.

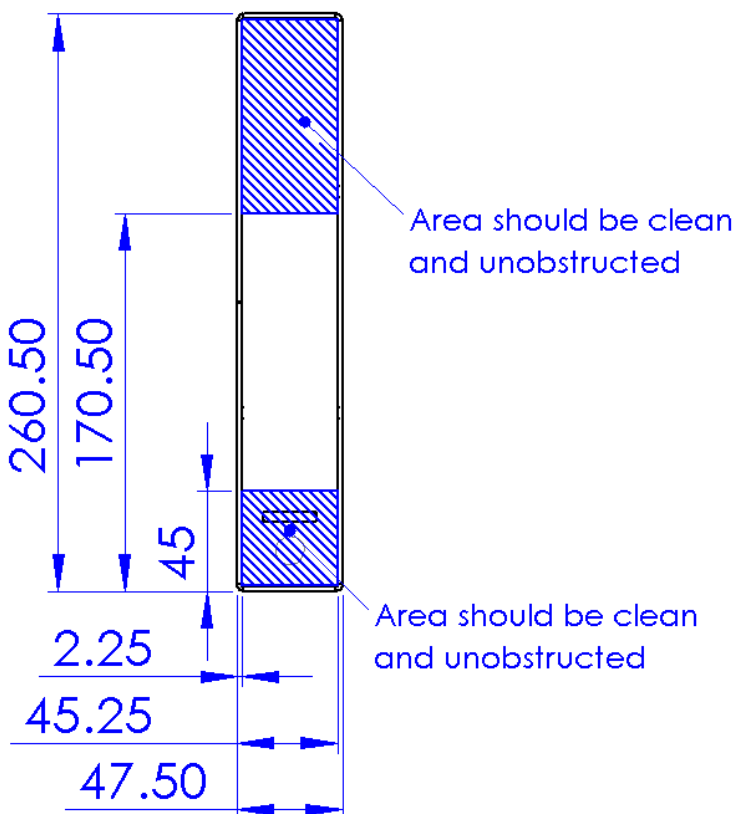

Figure 5: Cleaning and free area on PSI-D

The outer casing and screen can be cleaned with a soft cloth. The front screen has a hardened coating applied to prevent major scratches forming, however it is recommended not to use any abrasive pads or products when cleaning the device. It is important to keep the camera lens location free of scratches, obstructions or marks. If using cleaning products on the PSI-D, it is recommended to avoid any containing acetic acid (vinegars) and to apply cleaning fluid to a soft cloth first (not direct to unit).

Please note that the area on the front screen between the LED illumination and camera lens (between the blue shaded areas on figure 5) is a free area that does not affect the functionality of the system.

Contact Us

For further information about our products and solutions please feel free to contact us. This can be done through our website at <https://www.perception-si.com/contact-us>

Alternative you can call us on +44 (0) 1302 729126.

Copyright, Confidentiality, Compliance and Legislation Statement

This document is a strictly confidential communication to and solely for the use of the recipient. No part of this documentation or the products described in it may be reproduced, transmitted, transcribed, stored in a retrieval system or translated into any language in any form or by any means (except documentation kept by the purchaser for backup purposes) without the express written permission of Perception Sensors and Instrumentation Ltd. Specifications and information contained in this document are furnished for informational use only and can be subject to change at any time.

Copyright © Perception Sensors and Instrumentation Ltd.



Under United Kingdom Legislation Perceptions Sensors and Instrumentation Ltd. (PSI) is defined as a WEEE Business to Business (B2B) producer, selling its own branded hardware solutions to businesses within the United Kingdom. The company WEEE producer Registration Number is WEE/FB4237XX

PSI works in partnership with the WeeeCare compliance scheme to ensure legal responsibilities as defined within the WEEE Regulations are satisfied. WeeeCare is part of the WasteCare Group and aim to ensure the best available techniques are used for recycling and recovery of waste electrical and electronic equipment. PSI complies and are committed to meeting the requirements of the WEEE directive 2012/19/EU, which recasts the previous directive 2002/96/EC. The WEEE directive requires that manufacturers of electrical and electronic equipment, who sell into EU countries, label their equipment to notify customers that the item needs to be recycled and ensure that their products are appropriately disposed of or recycled at the end of their lifespan.

Safety notices:



Indoor Use Only

CAUTION Do not use this product near water.

Please use the 12V DC power supply unit provided with the product. The supply is a safety critical component of the product, replacement power supplies can be ordered through Perception Sensors and Instrumentation Limited.